

Cleaning Components for EMS Applications/Skids Program 0811/0815/0831

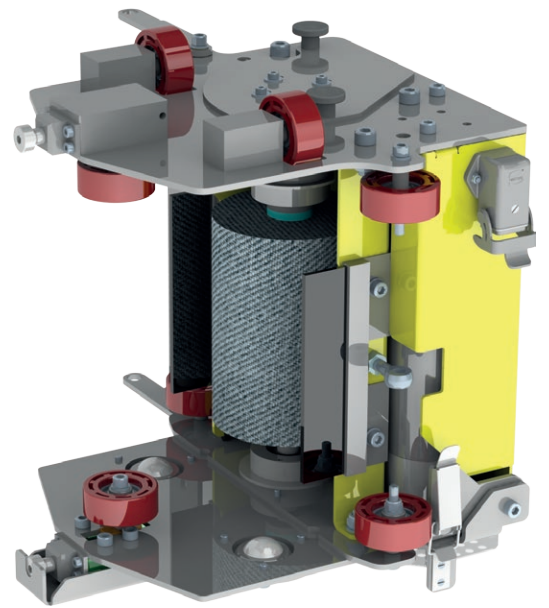
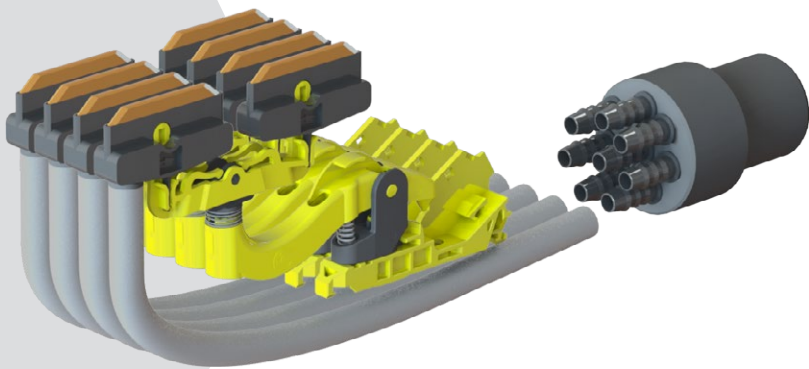

CONDUCTIX
wampfler

Complementary Documents

Product Catalogs:

KAT0815-0003-EN ProEMS Insulated Conductor Rail for Electrified Monorail Systems

Installation Instructions:

MV0815-0007-EN Installation Instructions for Conductor Rail System 0815

Operating Instructions:

BAL0800-0002-EN Rail Cleaner - 180x60, 180x80 and 240x80

Maintenance Instructions:

WV0800-0001-E Cleaning of Conductor Rails

WV0800-0004-EN Copper Rail Applications

Note

Subject to technical changes of the components described. The references to guidelines and standards listed in the document are subject to adjustments and must be checked for up-to-dateness. Classifications refer to general parameters and have to be evaluated case by case by the user.

Cleaning of Conductor Rails

Conductor rails use high-performance carbon brushes, which are aligned to the respective rail, and thus allow the lowest possible friction with simultaneous high power transmission. To protect the rail, the main wear part is the carbon brush. Depending on the environmental conditions and the mechanical quality of the systems, the carbon brushes have a mileage of up to 12,000 km, in some cases up to 20,000 km.

In operation, a fine abrasion is created, which settles in the rail and, due to the movement at transitions in the support structure, e.g. in the EMS support profile, accumulates.

The resulting dust in the rail or system should be removed by suction to prevent uncontrolled distribution. Depending on the application and type of conductor rail, different components are available for this purpose to assist cleaning.

Note:

Copper rails require an ideal running surface for optimum operation. The ideal state comes after some time by the conductor line being conditioned by the coal. The sanding process smoothes the surface and, at the same time, the diffusion of graphite forms a steel-blue to black track. This is called **patina** and **should under no circumstances be removed** (for example by using wire brushes or similar)!

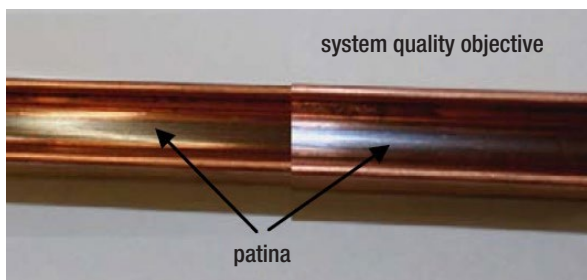

Fig.: track / patina

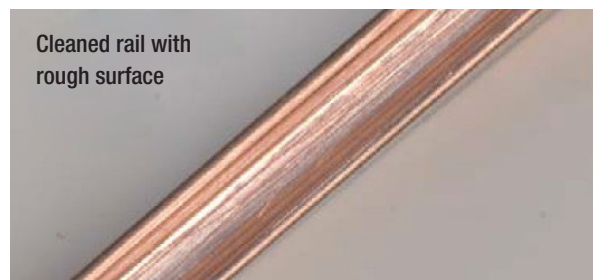

Fig.: damaged rail after using a wire brush to clean

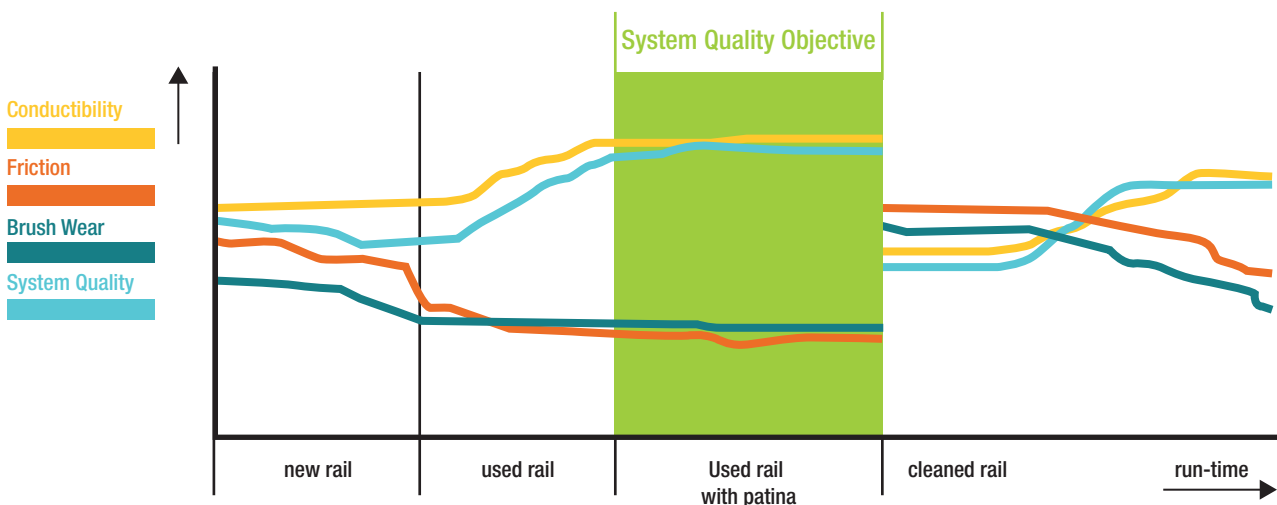

Fig.: system quality of copper rail

Cleaning Components

For overhead monorail systems there are two solutions for the defined extraction of dust from the conductor rail/conductor rail & EMS support profile:

- RailCleaner for extracting and removing adhering contaminants from the conductor rail and EMS profile
- EMSPro suction conductor for extracting the dust directly from the conductor rail

Contamination / Location	RailCleaner	Suction Conductor	Note
Loose dust in conductor rail	X	X	without rotating brush (Rail Cleaner)
Loose dust in conductor rail and EMS profile	X	–	
Adhesive contaminants in conductor rail	X	–	Rail Cleaner with temporarily inserted rotating brush
Burn marks on tread surface of the conductor rail	–	–	Replacement / Sanding
Oil or similar impurities in conductor rail	–	–	To be cleaned manually

- Suction Conductors are intended for mobile use and continuous suction.
- The RailCleaner, a chassis with suction bell, is preferably designed for mobile use.

All components have a standard hose interface (DN 40) for the suction connection for the transition to the extraction to be connected downstream (e.g. industrial vacuum cleaner for fine dust).

Cleaning Components

Suction Conductor for Conductor Rail Systems equipped with ProEMS 0815/0811

For removing dust from the conductor rails. The suction conductors are used like current collectors in the system but without the function of current transmission. The suction piece used is made of the same material as the current collectors.

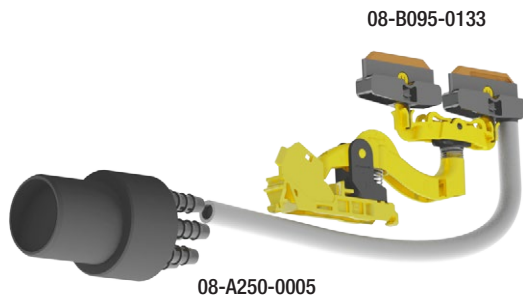

Example: Suction Conductor with pipe socket for EMS applications

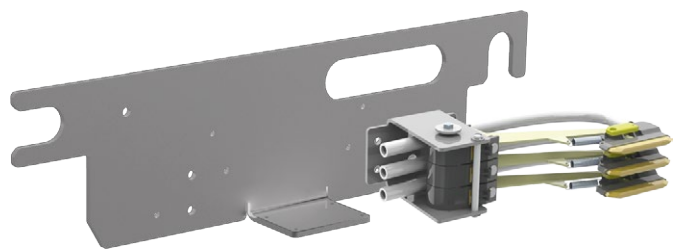

Example: Suction Conductor with exchangeable disc for skid applications

Available Versions

Part No.	Name	Description
08-B095-0128	Suction Conductor 0831	Short arm with square retainer incl. suction hose
08-B095-0130	Suction Conductor 0811	Arm with square retainer incl. suction hose
08-B095-0133	Suction Conductor 0815	ProEMS collector complete with suction hose
08-A250-0005	Pipe Socket	1-8 inlets/DN 40 outlet

Installation Base Plates for ProEMS Current Collectors can be used. See also catalog KAT0815-0003 „ProEMS for Electrified Monorail Systems“.

For further solutions for AS/RS, floor pallet conveyors, etc. please consult with Sales/Application Engineering.

Note: For cleaning, do not use wire brushes (damage to the running surface and short circuit on protruding or loose wires) or plastic heads (formation of an insulating layer on the rail).

During installation, as with the current collector, the installation position must be observed. The unit should be placed at the wheel contact point of the chassis in systems with curves / bends in order to avoid exceeding the permissible tolerances in the curves (inadmissible contact forces or loss of contact).

Cleaning Components

Cleaning Unit for Dust Extraction/Support Profile Cleaning (160 x 60 / 160 x 80 / 240 x 80)

Unit for the extraction of dusts from the support profile incl. conductor rail.

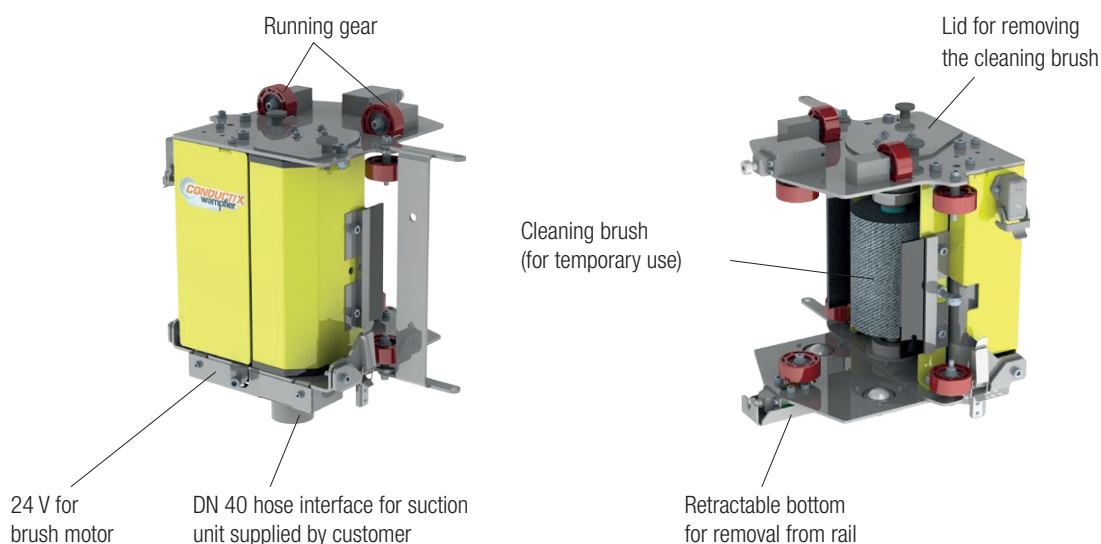

Components	EMS Support Profile		
	180 x 60	180 x 80	240 x 80
	Part No.		
Cleaning Head	08-G023-0138	08-G023-0135	08-G023-0183
Current Collector Housing (optional)	08-G023-0139	08-G023-0136	on demand
Control Unit (optional)	08-S210-0261	08-S210-0261	08-S210-0261
Connecting Plate (optional)	08-B020-7145		

See Operating Instruction BAL0800-0002 and Installation Instruction MV0800-0007

Using quick-release fasteners, the RailCleaner can be removed from the rail and put back in place within a few minutes. Thus cleaning is possible without the removal of vehicles. By pulling the RailCleaner with a pull rope, the cleaning can be done in sections.

To use the rotating brush (for temporary use when dealing with adhering dirt), a 24 V / DC supply or controls for manual operation (optional control unit) are required.

If the supply for the suction unit is to be made from the conductor rail, the optional current collector housing can be used. The structure corresponds roughly to that of the cleaning heads with quick-release fasteners, running and guide rollers for placing on the EMS profile.

Note: for systems with barcode or QR code tape, remove the bristles in the area of the code tape to avoid polishing the tape.

Cleaning Components

Basic Requirements for the Suction Unit/the Industrial Vacuum Cleaner for Carbon-Brushes' Dust

The Suction Units make depends on:

- Type and composition of the dust
- local specifications for industrial vacuum cleaners
- the required national dust class
- hazard classification of the dust
- available installation space

In addition, factory standards and manufacturer approvals as well as site regulations, e.g. workplace policies related to hazardous materials, noise emission and type of dust collector, and disposal have to be considered.

The following information is provided to help with the selection of the suction device.

We recommend contacting a manufacturer of industrial vacuum equipment.

Recommendation/Selection Parameters for Suction Device (European Union)

Suction Power: > 2500 l/min (2500 to 4500 l/min)

Filter Class: H

Safety:

- Filter monitoring (mandatory for class H)
- Antistatic-conduction incl. hose
- Sealable dust collector bag with filtered vent
- flow monitoring with shutdown/signaling in case of undercutting legitimate minimum flow rate of 20 m/s (EU)

Dust in Conductor Rails

The abrasion generated during operation consists to about 90% of graphite and copper, with small amounts of resins/additives (<3%), PVC, as well as compounds of these substances with the environment.

The particle size is between one and several microns. Since the fine components, similar to wood, gypsum, color or toner dust, must be classified as respirable when inhaled, the filter must be designed for particles <1 µm (filter class H).

The suction device must have a separate dust collector with disposal system for these dusts.

Discharge of static charges as well as filter monitoring are also to be provided for these suction devices.

It should be noted that process residues from the customer system collect in the conductor rail. These, and their possible connections, should also be considered when selecting the system.

Depending on the environment of the plant and the place of use, the requirements for occupational safety and the permanent establishment must be taken into account in accordance with local guidelines. These differ partly by country, but also by the areas of application in the company.

Note

Please see also „Complementary Documents“ (page 2)

www.conductix.com

Conductix-Wampfler

has just one critical mission:

To provide you with energy and data transmission systems that will keep your operations up and running 24/7/365.

To contact your nearest sales office, please refer to:

www.conductix.com/en/contact-search

