

F-Pickup 2.5 kW 560 V DC Q4/2 + Interface M12

Part Number

91212-332-3050777	2.5 kW F-Pickup 560 V DC Q4/2+Interface M12, side mounted
91212-332-3050780	2.5 kW F-Pickup 560 V DC Q4/2+Interface M12, top mounted
91212-332-3203145	2.5 kW F-Pickup 560 V DC + IF, side 90°

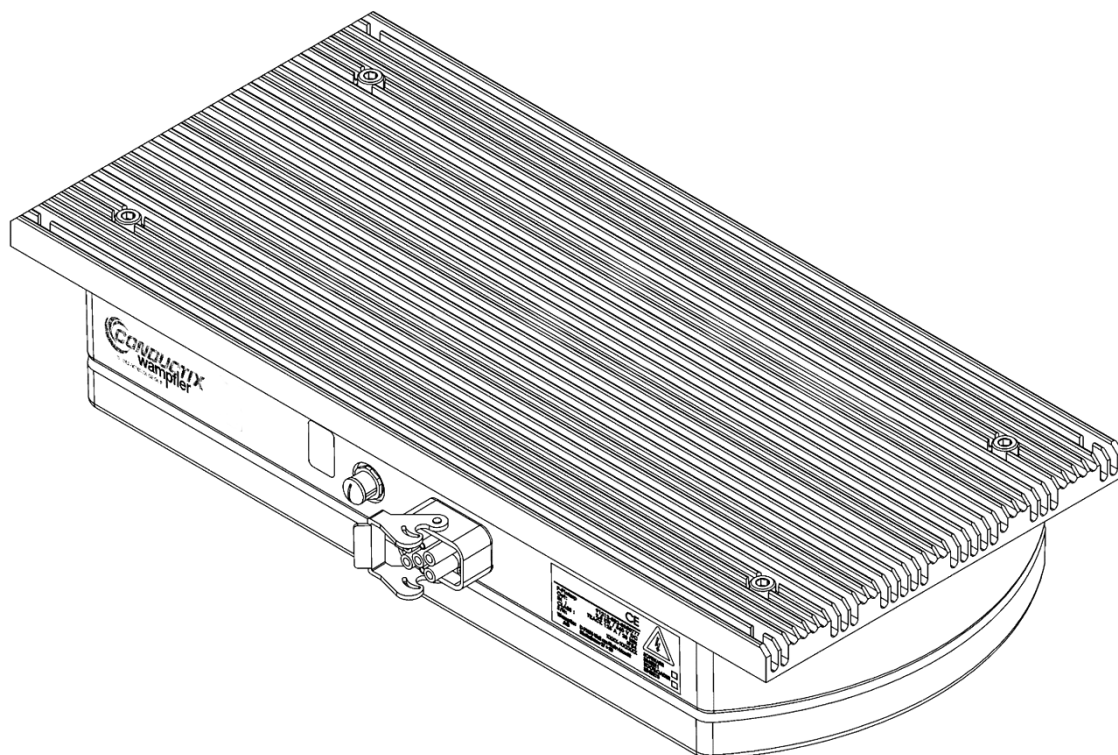

Version shown: 91212-332-3050777





Contents

- 1 General Advice 5
 - 1.1. Information to these Installation and Operating Instructions 5
 - 1.2. Limitation of Liability 5
 - 1.3. Copyright 6
 - 1.4. Replacement Parts 6
 - 1.5. Material Defects 6
 - 1.6. Technical Support 6
- 2 Safety Instructions 7
 - 2.1. Definition of Symbols 7
 - 2.2. Personnel Requisition 8
 - 2.2.1. Qualification 8
 - 2.2.2. Unauthorized Persons 8
 - 2.3. Advisory Information for the User 9
- 3 Intended Purpose 9
- 4 Technical Data 10
 - 4.1. Electrical Data 10
 - 4.2. Environmental Data 11
 - 4.3. Protection Measures 12
 - 4.4. Mechanical Integration 12
 - 4.5. Electrical Connections 16
 - 4.5.1. Connection of Power Output 16
 - 4.5.2. Connection of Interface 17
 - 4.5.3. Ground Connection 17
 - 4.5.4. ESD Protection 17
- 5 Scope of Delivery 17
- 6 Transport, Packing and Storage 18
 - 6.1. Transport 18
 - 6.1.1. Safety Advice for Transport 18
 - 6.1.2. Transport Inspection 18
 - 6.2. Packing 19
 - 6.3. Storage 19



F-Pickup 2.5 kW 560 V DC
Q4/2 + Interface M12

- 7 Installation 20
 - 7.1. Who is authorized to carry out the Installation? 20
 - 7.2. General Advice for the Installation 20
 - 7.3. Electrical Regulations 20
 - 7.4. Recommended Connection 21
 - 7.4.1. Connection of Pilot Pins 21
 - 7.4.2. Example: Using the Interface 22
 - 7.4.3. Example: If the Interface is not used 23
 - 7.5. Place and Conditions of Installation 24
 - 7.5.1. Position 24
 - 7.5.2. Air Flow Required 25
 - 7.5.3. Proximity to Iron/Steel 25
 - 7.5.4. Attachment Points 26
 - 7.5.5. Additional mechanical Protection 26
- 8 Operation 27
 - 8.1. Powering up 27
 - 8.2. Powering Down 27
 - 8.3. Positional Tolerances 28
 - 8.4. Parallel Operation of Pickups 28
 - 8.5. Maximum Number of Pickups on a Track 29
 - 8.6. Tips for Operation with the Interface 29
 - 8.7. Precautions 30
- 9 Warnings and Cautions 31
- 10 Fault and Diagnose 32
 - 10.1. Basics 32
 - 10.2. Normal State 33
 - 10.3. Signals and Meanings 33
 - 10.4. Reset 35
- 11 Maintenance 35
- 12 Repair 36
- 13 Disassembly and Re-Use 36
 - 13.1. Safety Advice for Disassembly and Disposal 37
 - 13.2. Recycling 37



F-Pickup 2.5 kW 560 V DC
Q4/2 + Interface M12

14 Accessories..... 38

14.1. Power Output..... 38

14.2. Interface..... 39

15 Tools 40

Important:

Company names and trademarks mentioned in this manual that are registered and protected trade names by copyright do remain the property of the companies themselves.

We reserve the right to carry out technical modifications of illustrations and statements in these operating instructions, in order to improve the energy supply system and its function.

System related details please find in the system manuals. Refer always to the system documentation before starting any work on the system or components within the system or before operating the system.

Reprint and duplication (as well as extracts) are only allowed with permission from Conductix-Wampler GmbH.

This Operating Instruction is based on the following Technology-Documentation-No.: OM9100-0113e-EN!

© Conductix-Wampler GmbH 2017

1 General Advice

1.1. Information to these Installation and Operating Instructions

These installation and operating instructions allow the safe and efficient handling of the equipment.

The installation and operating instructions are part of the equipment and must be stored close to the equipment and always available to the personnel. The personnel must have read carefully and understood these installation and operating instructions prior to starting any works. The basic requirement for safe working is the observance of all safety advice and guidelines specified in these installations and operating instructions.

Moreover, you have to observe the local accident prevention guidelines and the general regulations for the application of the equipment.

Illustrations in this documentation are for basic comprehension and can deviate from the real design of the equipment. All stated values are based on the metric system. If units of measurement have been omitted, millimeters (mm) apply. According to ISO 2768, our dimensions are in tolerance class v (very coarse).

Complementary instructions given in track installation manuals for specific applications, i.e. MV9100-0038 for EMS systems, must be observed at all times, if of relevance for the installation and operation of the equipment. Design, adjustment and commissioning may only be carried out by trained personnel of Conductix-Wampfler.

1.2. Limitation of Liability

All specifications and advice of these installation and operating instructions have been compiled with regard to existing standards and prescriptions, the state-of-the-art and the many years of technical expertise and experiences.

The manufacturer is not liable for damage due to:

- Non-observance of the installation, and operating and maintenance instructions
- Improper use
- Application not in accordance with the regulations
- Use by untrained personnel
- Unauthorized modifications
- Technical modifications
- Use of unauthorized spare parts and accessories

The effective volume of delivery may deviate from these explanations and descriptions in case of special design, the utilization of additional order options or on account of to the latest technical modifications.

The obligations agreed upon in the delivery agreement and our General Terms of Business apply, as do the delivery conditions of the manufacturer and all regulations applicable at the time the contract was concluded.

We reserve the right of technical modifications in the context of revision of useful properties and further developments.

1.3. Copyright

These installation and operating instructions are subject to copyright and intended for customer internal use only. Provision of the installation and operating instructions to third party, any type of copying - even in extracts - as well as utilization and/or communication of the contents are not permitted without written approval by the manufacturer, except for customer internal purposes.

Violations will cause indemnities. We reserve the right to further claims.

1.4. Replacement Parts



Safety risk due to faulty replacement parts!

Faulty or defective replacement parts might affect the security and cause damage, malfunction or complete failure.

→ Use only original replacement parts of the manufacturer!



The product warranty expires with the use of unauthorized spare parts. Spare parts must be ordered from your licensed dealer or directly from the manufacturer. Address see last page of these instructions.

1.5. Material Defects

The regulations about material defects are listed in the general business conditions of the manufacturer. If not otherwise agreed the general business conditions of Conductix-Wampller GmbH apply. For purchased parts, the respective conditions of the manufacturer apply.

1.6. Technical Support

Our customer service is available for technical support. For contact data see last page of these instructions. Moreover, our employees are always interested in new information and experiences from the field that can be valuable for the improvement of our products. Please also contact our customer service in this context.

2 Safety Instructions

2.1. Definition of Symbols

Safety advice in these installation and operating instructions is marked by symbols. Safety advice start with signal words, that inform about the degree of danger. Safety advice must be absolutely observed. Exercise caution in order to avoid accidents, personal injury and damage to property!



DANGER!

... refers to an imminent danger, which might cause deathly or serious injuries if not avoided.



WARNING!

... refers to a possibly dangerous situation, which might cause deathly or serious injuries if not avoided.



CAUTION!

... refers to a possibly dangerous situation, which if not avoided, may result in moderate or minor injury and property damage.



ADVICE!

Advice and recommendations:

... gives advice and recommendations as well as information for an efficient and undisturbed operation.

Special security advice

The following symbols are used to point out special risks:



DANGER!

This combination of symbol and signal word indicates an imminent dangerous situation caused by electrical power and/or electrical voltage. If a labelled hint like this is not observed, this may result in heavy or deadly injuries.



WARNING!

This sign draws the attention to parts of the operating instructions, where special care must be taken on account of hot surfaces or of inductive heating of ferromagnetic material and where other special measures have to be taken.

To achieve fault-free operation and any rights to claim guarantee it is necessary to observe and fulfill the information given in this document or related documents at any time. Read instructions entirely before starting any work and operation of the device. This document contains operation related information. It is therefore recommendable to keep it in the vicinity of the device. Please pass on the corresponding advice to other users, too.

2.2. Personnel Requisition

2.2.1. Qualification



Risk of injury due to insufficient qualification!

Improper use can result in serious injury to persons and property damage.

→ All installation and commissioning works and for maintenance and dismantling must be carried out by qualified personnel (observe IEC 364 resp. CENELEC HD 384 or DIN VDE 0100 and IEC 664 or DIN VDE 0110 and the national accident prevention regulations).

The following qualifications are listed in these operating instructions for different areas of operation:

- **Instructed personnel/operators**
have been instructed by the operator about the tasks assigned to them and the possible dangers due to improper behavior.
- **Specialized staff**
is able to carry out the works assigned to them and realize and avoid any dangers in this regard, based on their training, knowledge, experiences and knowledge of the respective regulations.
- Only those persons are authorized for these works, who are expected to do their work properly. Persons with restricted responsiveness, e.g. due to drugs, alcohol or medication are not permitted.
- For the selection of personnel observe the age-specific and job-related prescriptions effective at the place of installation.

2.2.2. Unauthorized Persons



Danger due to unauthorized personnel!

Unauthorized personnel, who do not meet the requirements described hereunder, are not familiar with the dangers that might occur within the working area.

- Keep unauthorized personnel away from the working area.
- In case of doubt, address the persons and direct them away from the working area.
- Stop work and establish a safe state as long as there are unauthorized persons within the working area.

2.3. Advisory Information for the User



This device contains life threatening voltages. Improper handling/operation or faulty installation can result in electric shocks and/or burns as well as material damages. There are no user serviceable parts in the device. Do not open, do not insert any objects inside.



All electric installation and commissioning work as well as repair work and disassembly have to be carried out by qualified staff (IEC 364 respectively CENELEC HD 384 or DIN VDE 0100 and IEC 664 or DIN VDE 0110 and national safety rules).



Qualified staff according to the safety regulations are persons that are familiar with the installation, assembly, commissioning and operation of the energy supply system and that have the appropriate qualifications.

Conductix-Wamplifier cannot be responsible for damage and breakdown that have been caused by not observing this manual.

This manual contains exclusively details of the specified pickup.

Observe all instructions and technical data given in this document. Ensure that the device is operated under the specified conditions only.

Do not start up the device or related devices within the system until you have made sure that the machine/system it is integrated into complies with the applicable norms, standards and directives and that conformity is stated.

We reserve the right to carry out technical modifications of illustrations and statements in this instruction manual. References to other documents specifying the document number do not include the revision index. Refer to the project handbook when available for a list of relevant documents.

Unless specified differently, all data refer to the metric system, i.e. lengths are always in millimeter. Units used are based on European standards.

3 Intended Purpose

The intended purpose of this device is for use in conjunction with other components for the contactless transfer of electrical power.

A pickup produces a DC voltage output from the AC magnetic field generated by a track.

The device is not suitable for standalone operation and must be used in conjunction with the appropriate components.

Qualified personnel only may operate this equipment.

4 Technical Data



CAUTION!

The data specified in this section are valid only if the requirements regarding the environment of the device (position, ambient temperature, etc....) are respected.

For instance, the layout of the track, the variations with respect to nominal position of a Pickup, or the ambient temperature around a regulator, may lead to a reduction of the peak and/or continuous power available.

4.1. Electrical Data

- Input Track: 125 A, 20 kHz, conductor spacing 100 mm
- Output voltage 560 V DC +/-25 V AC
- Peak output power 2,5 kW for nominal position and under adequate conditions of operation (See chapters 7.5 and 8.3).
- Continuous output power 1 kW at 40°C ambient = 40 % duty cycle*
1.5 kW at 25°C ambient*
* over 10 minute periods, air convection 0.1 m/s and nominal position (see chapter 7.5).

- Output current maximum 5 A DC
- Heat loss approximately 150 W at full load.
- Electrical protection Class II (reinforced internal insulation).
- Insulation to ground Power output to ground tested at 5 kV DC/5 seconds.
Power output to interface tested at 5 kV DC/5 seconds.

4.2. Environmental Data

- Storage temperature -20°C to +60°C
- Transport temperature -40°C to +80°C
EN 60721-2-2 | Class 2M2
- Ambient temperature +0°C to +40°C
EN 60721-3-7 | Class 7K3
Air temperature as measured in immediate vicinity of working device. Please note that the heat loss of the pickup will raise the ambient temperature, especially in enclosed mounting spaces.
- Humidity < 95%, non-condensing
- Vibration *EN 60721-3-7 | Class 7M1*
- Chemical resistance For industrial use without special conditions.
Any specific influences of chemicals must be checked.
- Protection rating IP54 (when plugs are in place)
EN 60529
- EMC environment The device is designed for use in industrial environments (EN55011 Class A)
EN 61000-6-2 | Class A
EN 61000-6-4 | Class A
- Installation altitude Up to 1000 m; continuous output power must be derated for higher altitudes

The use in explosion-proof areas or in areas where the device is exposed to harmful oils, acids, vapors, dust, gases, radiation, humidity, etc. is explicitly forbidden.

For indoor operation only!

4.3. Protection Measures

The pickup is protected against the following events:

- Over voltage Automatic shutdown if the voltage supplied by the pickup > 610 V.
Output protected up to 850 V (no reserve polarization)
- Disconnected DC output Automatic shutdown when unplugged/disconnected:
Protection against DC contact arcing; output voltage is removed.
Unplugging under load is not recommended (proper wiring of the pilot pins: see chapter 7.4).
- Over current Is current limited
Automatic shutdown on strong overload or output short circuit i.e. voltage < 100 V.
A high transient over current i.e. a sudden short circuit will damage the device.
- Reverse current Protected against reverse current flow -
but not protected against reversed polarization i.e. reverse battery connection.
- Over temperature Automatic shutdown on internal over temperature i.e. as a consequence if maximum rated temperature and/or maximum average output power are exceeded.
- Repetitive shutdowns Shutdown procedures (i.e. turning off the pickup through the interface plug) discharge internally the energy stored inside the pickup. To avoid overheating, the number of shutdown procedures is limited to 3 within 30 seconds. This number exceeded, the pickup will remain in disable mode and respond only passed a delay of 30 seconds.

4.4. Mechanical Integration

- Dimensions See drawing
- Weight 16,9 kg (without attached cable)
- Surface temperatures Heat sink surface temperature may reach up to 70°C depending on operating conditions
- Nominal air gap All data are specified for a distance between the floor and the bottom of the pickup of 10 mm. If the installation manual for floor systems has been followed, this distance corresponds to 15-16 mm between the bottom of the pickup and the top of the track cable. See chapter 8.3 for more information regarding tolerances.

Operating Instruction



F-Pickup 2.5 kW 560 V DC Q4/2 + Interface M12

Version 91212-332-3050777

(Bottom view)

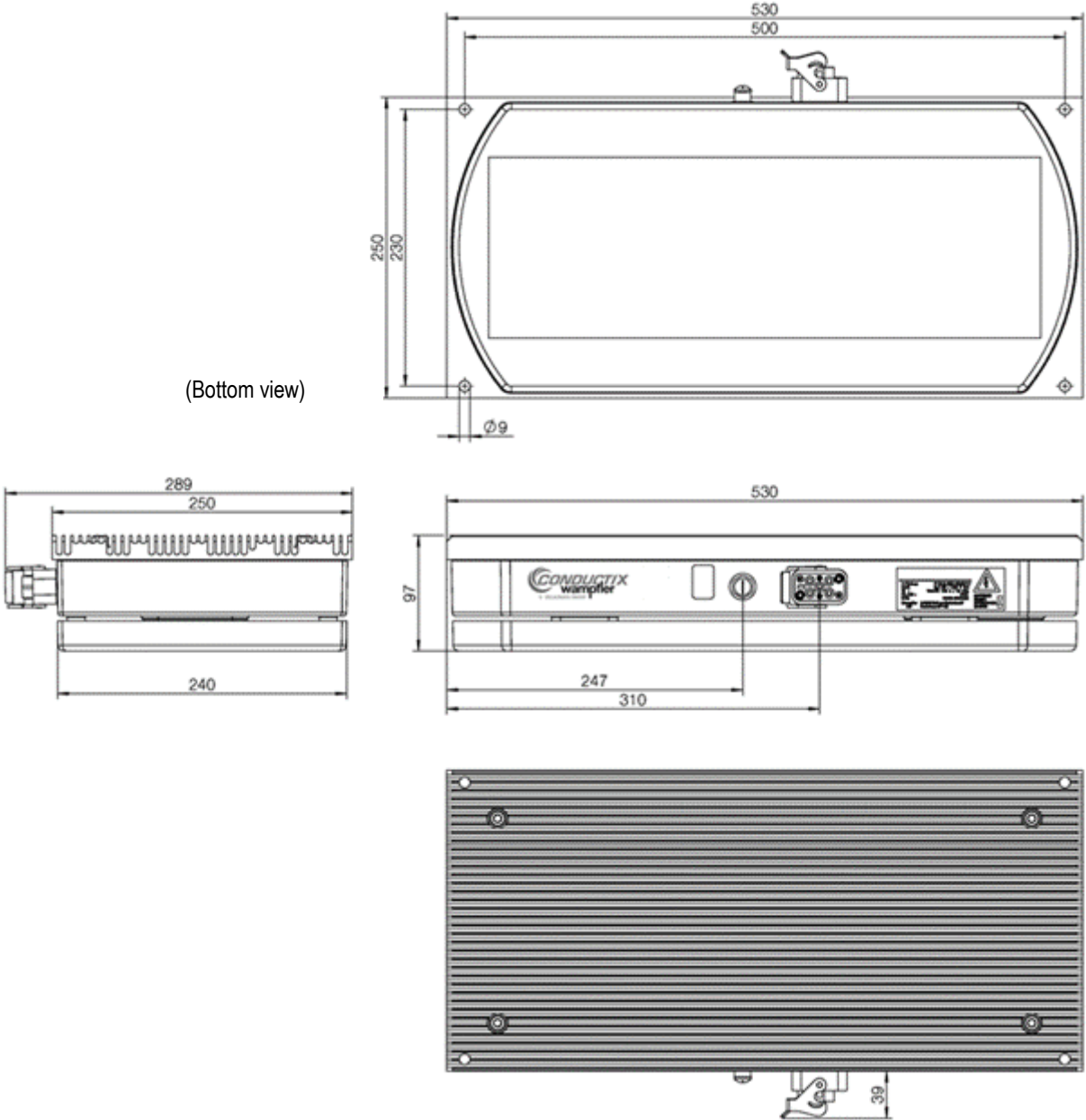

Operating Instruction



F-Pickup 2.5 kW 560 V DC Q4/2 + Interface M12

Version 91212-332-3050780

(Bottom view)

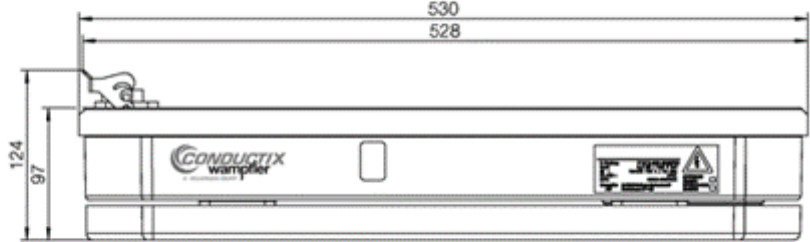
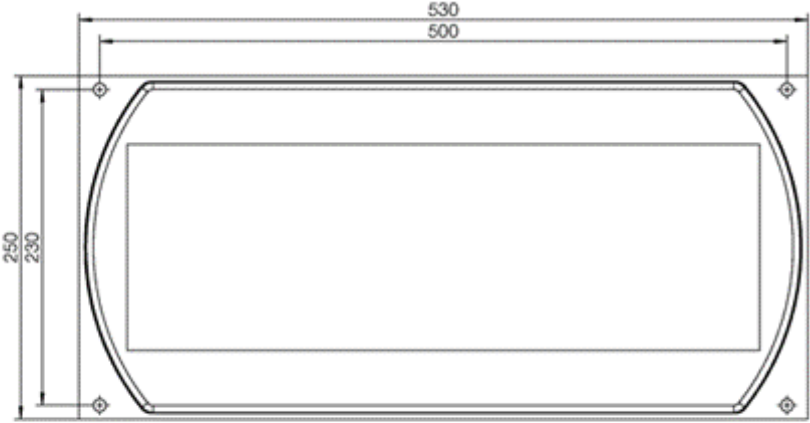
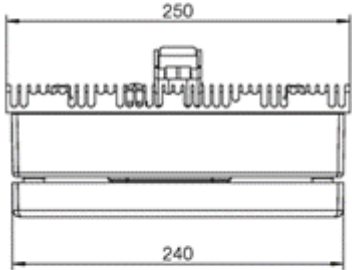

F-Pickup 2.5 kW 560 V DC
Q4/2 + Interface M12

Version 91212-332-3203145

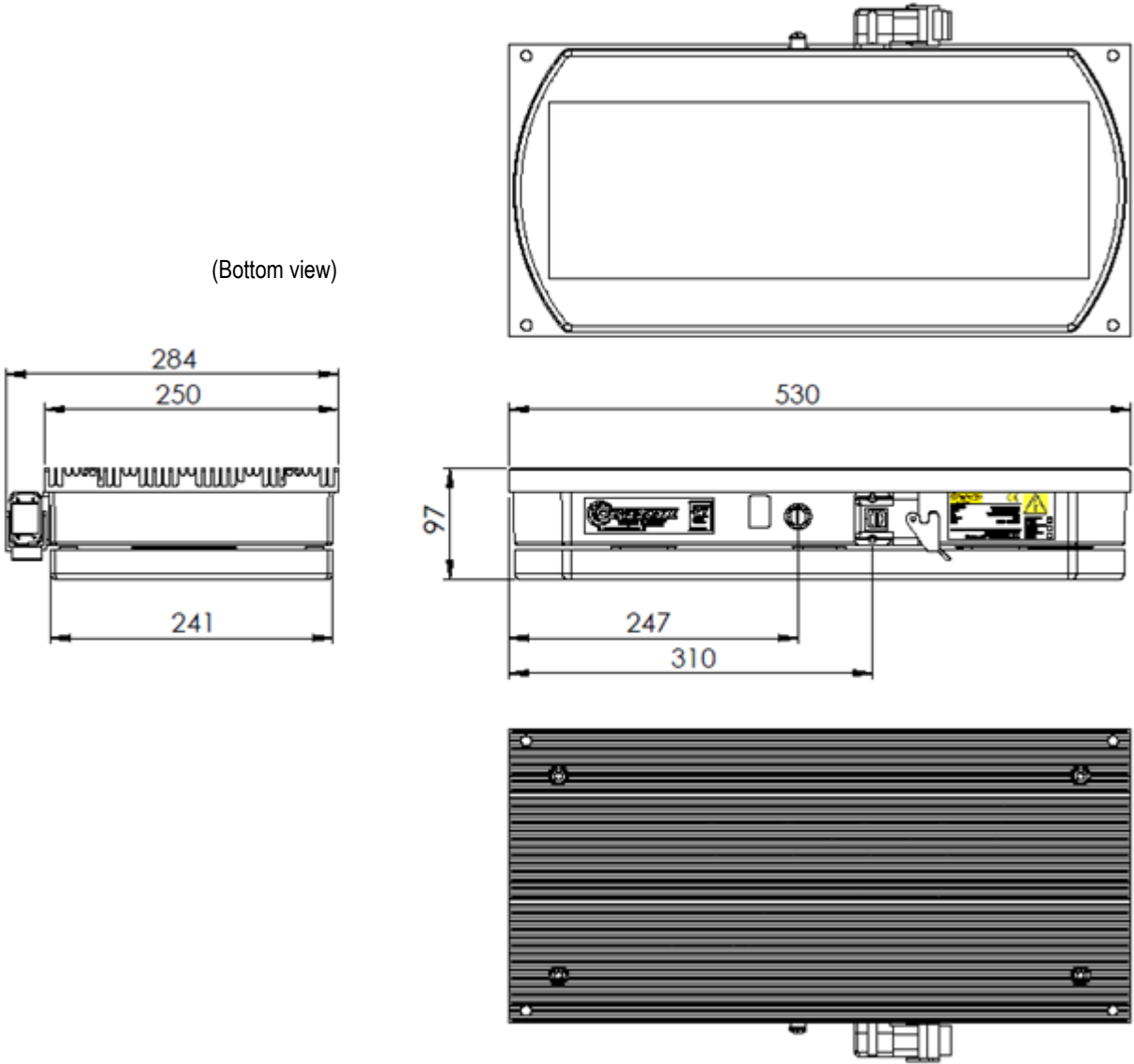

F-Pickup 2.5 kW 560 V DC Q4/2 + Interface M12

4.5. Electrical Connections

- DC power output HAN Q4/2 (Harting) or CQM04/2 (Ilme)
- Interface SACC-E-M12FS-8CON (Phoenix) or series 763/8-pole (Binder)

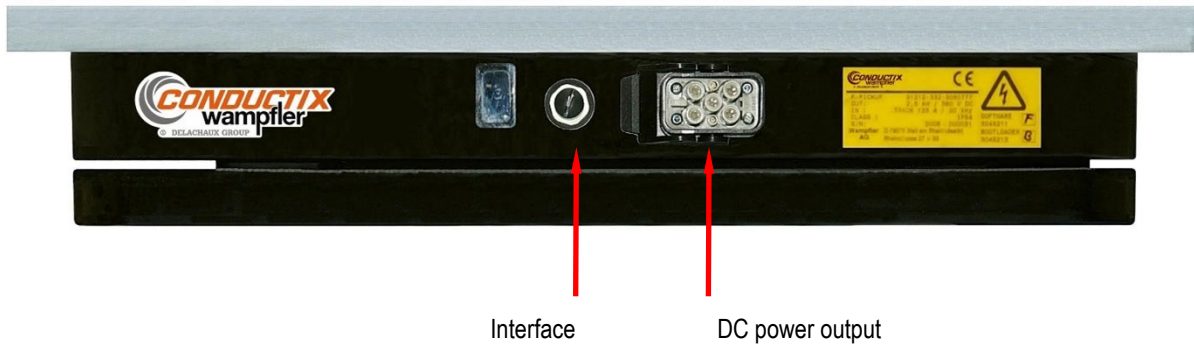

Shown here is material number 91212-332-3050777. Position/number of connectors may differ according to the version ordered.

Connection cables can be ordered separately. Refer to chapter 14.

4.5.1. Connection of Power Output

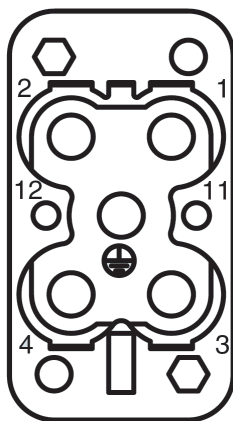

(view: contact side)

PIN 1 -> DC+ out
PIN 3 -> DC- out
(Power output 560 V DC)

PIN 2 -> AC 1
PIN 4 -> AC 2
(AC1 and AC2 are used for commissioning only! No cable should be connected to these pins.)

PIN 11 -> Pilot 1
PIN 12 -> Pilot 2
(Pilot 1 and 2 pins must be shorted to allow pickup to power up - refer to chapters 7.4, 8.1. and 8.2)

PIN  -> Ground

F-Pickup 2.5 kW 560 V DC Q4/2 + Interface M12

4.5.2. Connection of Interface

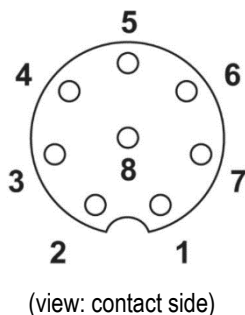

PIN 1	-> Isolated 24 V DC
PIN 2	-> Isolated 0 V DC (150 mA maximum. Do not distribute externally: see chapter 8).
PIN 3	-> COM (common to the 3 output relays "Warning", "Error" and "Status")
PIN 4	-> Enable (Must be connected to allow the pickup to power up! See chapter 8).
PIN 5	-> Warning
PIN 6	-> Error
PIN 7	-> Status (Relays have potential free contacts, rated for 30 V DC/5 A maximum)
PIN 8	-> Ground

All pins are isolated from the main power output.

4.5.3. Ground Connection

All electrical equipment must be connected together to the vehicle frame to ensure an equipotential bonding. The ground output of each plug must therefore be connected. In the same way, make sure to connect the heatsink of the pickup to the vehicle frame (GND) and not rely only on the connection to ground provided by the power connector. The reason is that if the connection to the load is removed while the primary is active, then the pickup is still internally energized though the ground connection is broken. Be sure to ground the heatsink as well as the ground output of each plugs.

4.5.4. ESD Protection

Because the system is isolated, some electrical charges may accumulate on the vehicle depending on the surrounding conditions and the vehicle design. An adequate solution must be foreseen using a conductive floor coating together with for example conductive brushes, sliders, track rollers, wheels or similar methods for a connection to earth, in order to reduce the likelihood of static charge build up and therefore ensure protection against electrostatic discharge (ESD).

5 Scope of Delivery

Cables and plugs, as well as material for mounting the device to a supporting structure (i.e. screws, etc.) are not included in the scope of supply. Refer to chapter 14 for more information.

6 Transport, Packing and Storage

6.1. Transport

6.1.1. Safety Advice for Transport



Damage from improper transport!

Improper transport can result in substantial property damage.

- Act with care when unloading the packaged unit as well as during internal transport, and observe the symbols and the hazard information on the packaging.
- Use only the attachment points provided.
- Remove packaging only shortly before installation.

6.1.2. Transport Inspection

Delivered goods must be checked for completeness and transport damage immediately after arrival.

If any transport damage is recognizable from the outside, proceed as follows:

- Do not accept the delivery or only with reservation.
- Note extent of damage on the transport documents or on the delivery note of the carrier.
- Initiate complaint.



ADVICE!

Complain about each fault, as soon as you have noted it. Claims for damages can only be raised within the respective terms.

6.2. Packing

The individual packages have been packed according to the expected transport conditions. We have used environmentally sound packing material only.

The packing shall protect the individual components up to the assembly from transport damage, corrosion and other kind of damage. This is the reason why the packing material should not be destroyed and only be removed immediately before starting with the assembly. For onward transport or return, it must be made sure that a packaging at least equal to the arriving transport packaging is being used and that the packages are correctly labelled.

Handling of packing material:

Dispose of packing material according to the respective legal regulations and local prescriptions.



Environmental damage due to incorrect disposal!

Packing materials are valuable raw materials and can be re-used in many cases or can be sensibly recycled.

- Packing materials are to be disposed of environmentally correctly.
- Observe the local disposal regulations; if necessary, commission a specialist company for the disposal.

6.3. Storage

Store packages under the following conditions:

- Do not store in the open air.
- Keep in a dry and dust-free atmosphere.
- Do not expose to aggressive media.
- Protect from solar radiation.
- Avoid mechanical vibration.
- Storage temperature: see chapter 4.2.
- Relative humidity: max. 60%.
- In case of a storage time of more than 3 months, check the general condition of all parts at regular intervals. If required, refresh and renew the preservation.



In case goods are delivered with specific storage instructions or specific hints on the package, those must be observed. They may overrule the above requirements if they are more demanding than the above requirements.



Risk of damage of the device!

If the storage or ambient temperature is below 10 °C or if the storage or ambient temperature deviates by more than +/-15 °C from the operating temperature, the device must be left de-energized and switched off for at least 12 hours. We generally recommend a 12 hour rest period in a power-off and de-energized state at operating temperature prior to installation and commissioning. Ideally, installation and commissioning are to be carried out at a temperature range from 10 °C to 30 °C.

7 Installation

7.1. Who is authorized to carry out the installation?



All installation and commissioning work as well as maintenance work and disassembly have to be carried out by qualified staff (IEC 364 respectively CENELEC HD 384 or DIN VDE 0100 and IEC 664 or DIN VDE 0110 and national safety rules).



Qualified staff according to the safety regulations are persons who are familiar with the assembly and installation of the energy supply system and who have the appropriate qualifications.

7.2. General Advice for the Installation



After receipt of the components, and prior to starting the installation work:

- Unpack the components and check carefully for damage that may have occurred during transport or storage (damage to housings and insulation, missing parts etc.).
- Check data on the identification plate to make sure that the components meet the requirements with regard to nominal power and voltage.
- Check completeness of the documents and conformity with the delivered components.
- Pickups have to be installed on an even surface and in a permanently safe position. An improper installation of the energy supply system has a negative impact on the function, the efficiency and the lifetime of the device. It is therefore important to observe the specification for the choice and place of installation. The guarantee will expire if this is not observed!

Follow the instructions of chapter 7.5 for attaching the pickups to the support structure. See also chapter 4.5.3 for making the connection to ground.

7.3. Electrical Regulations



The general electrical operating conditions according to VDE 0100 (installation and operation of electrical equipment up to 1000 V) have to be observed. If necessary apply the local regulations when they go beyond or differ from these requirements.

7.4. Recommended Connection

7.4.1. Connection of Pilot Pins

Shorter pilot pins are used in the power connector (pickup side) to provide a signal to the pickup when the load is connected. Breaking the pilot connection while unplugging will signal to the pickup to shut down before the main contacts are disconnected, thus preventing DC arcing in the connectors (protection measure presented in chapter 4.3).

If the pilot signal is shorted in the plug on the pickup side, the pickup will not be able to detect when the cable is disconnected at the load side. No protection against DC contact arcing can be expected in this case, nor would the output voltage be disabled once the cable is disconnected. This could result in an unsafe situation.

In order to fully use the benefits of the pilot pins in case the power output cable is disconnected, we recommend shorting the pilot pins on the side of the load connected to the pickup. Only this way is it assured that the pickup switches off when the cable is disconnected, be it on the pickup side as well as on the load side. Refer to following examples for more details.

F-Pickup 2.5 kW 560 V DC Q4/2 + Interface M12

7.4.2. Example: Using the Interface

Below is an example of connection presenting pickup version 91212-332-3050777 (also valid for versions 91212-332-3050780 and 91212-332-3203145) when both the power output and the interface connection are used.

The interface connection allows turning on and off the pickup even under load and provides as well an easy way to reset the device in case a fault has been detected. These basic functions are fulfilled by the switch connected between pins 1 and 4 on the vehicle side. Due to the low voltages involved and the isolated characteristics of the interface connections, the switch requires very basic isolation and ratings (24 V DC/0.1 A).

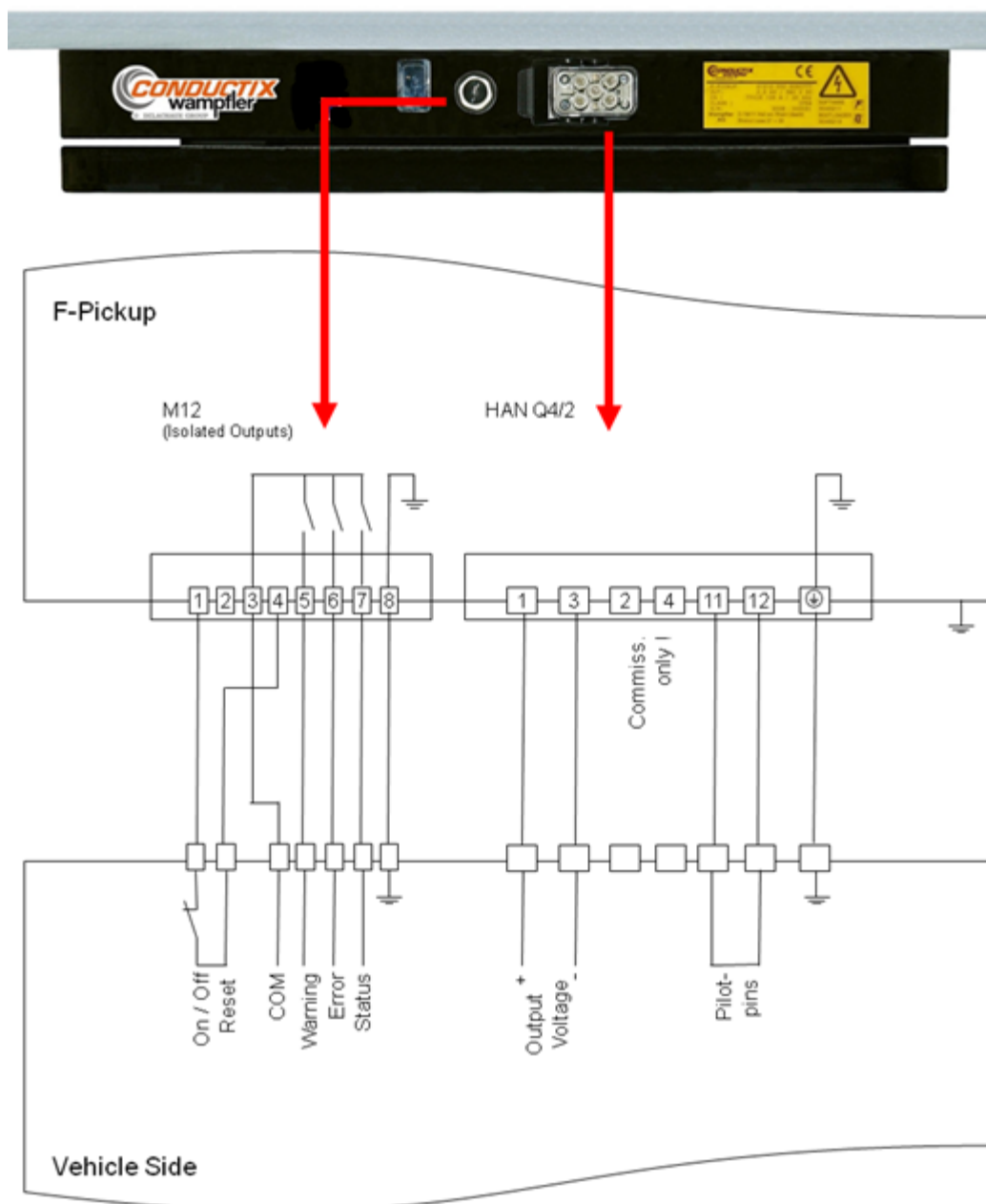

Initial status of relays, please see chapter 10.

F-Pickup 2.5 kW 560 V DC Q4/2 + Interface M12

7.4.3. Example: If the Interface is not used

Below is an example of connection with pickup version 91212-332-3050777 (also valid for versions 91212-332-3050780 and 91212-332-3203145). **Even if signals available through the interface plug are not being used, it is still necessary to connect pin 1 to pin 4 for the pickup to start (e.g. with "Enable plug set" 9100-400-3089971).** See also chapter 14.2 for more information.

Pilot pins are not designed to be used as an ON/OFF switch and it is thus recommended not to open the pilot connection under load. However, disconnecting the pilot pins will reset the pickup. Therefore, this procedure can be used to reset a fault in case of automatic shutdown. This is the purpose of the switch shown in the following illustration, connecting pins 11 and 12 on the load side. Refer to chapter 10 "Fault and diagnose" for more information. Voltage present on the pilot pins is not isolated from the main output power. Make sure to use a switch with suitable isolation to ground. Rating between contacts is 24 V DC/0.1 A.

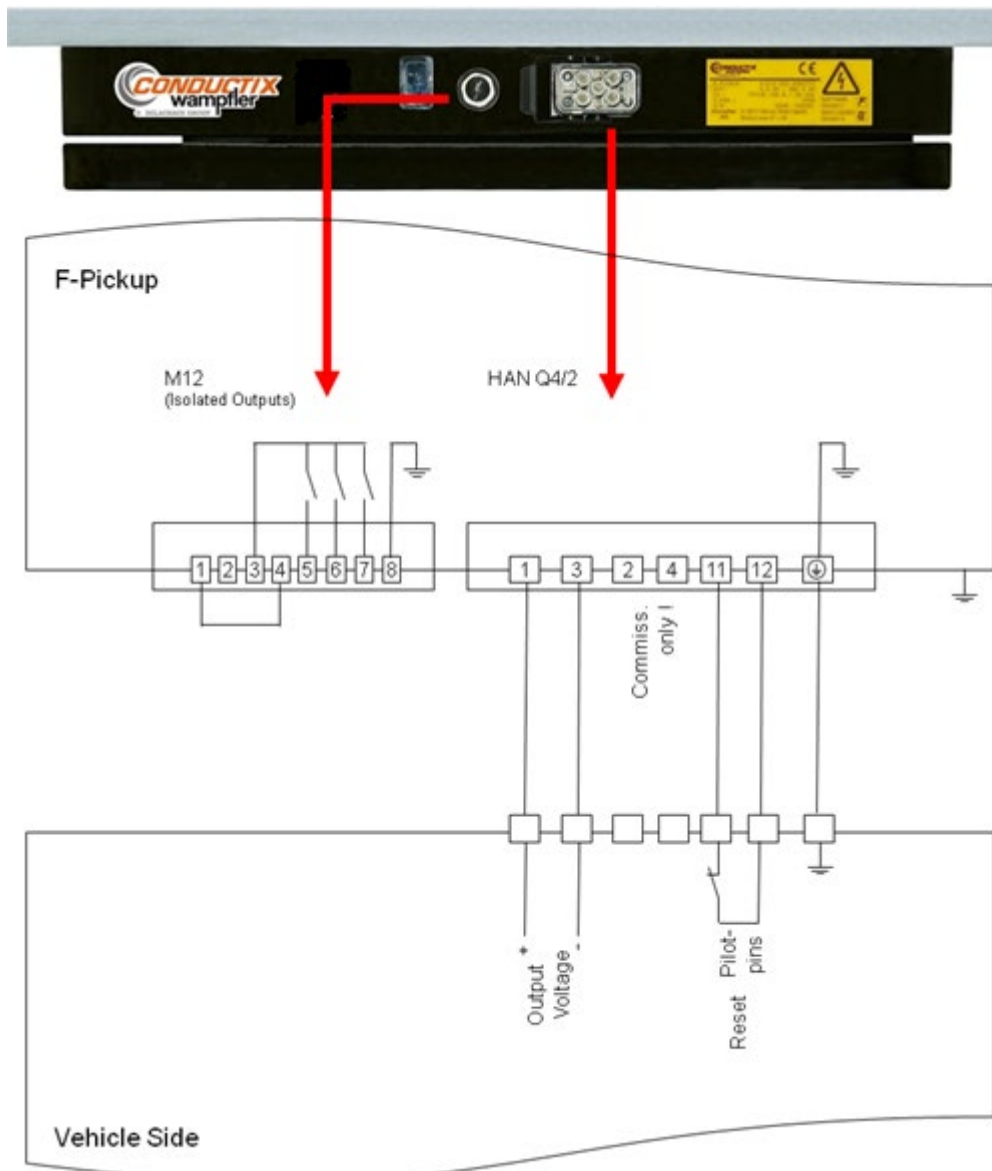

Initial status of relays, please see chapter 10.

7.5. Place and Conditions of Installation



Install the pickup in an environment and under conditions as specified in this document only. The pickup is to be mounted in a horizontal position, heatsink on top and attached to a solid base.



Ensure free space around pickup, to prevent the influence of ferromagnetic material as well as to provide sufficient cooling air circulation.

Available output power as specified in this document strongly depends on the ambient conditions of the device. Refer to chapter 4.1 for more information.

7.5.1. Position



A horizontal position is recommended to maximize the efficiency of convection cooling. If the pickup is positioned with an angle, i.e. not horizontal, the maximum average power available may be reduced. Positions where the heat sink is facing down are not allowed.



Pickups are to be mounted parallel to the primary track and centered between the cables (illustrated below). There should be a 10 mm air gap between the bottom of a pickup and the surface of the floor (provided that the primary track cables are installed as specified in the installation manual for floor systems) in order to ensure the specified output power.

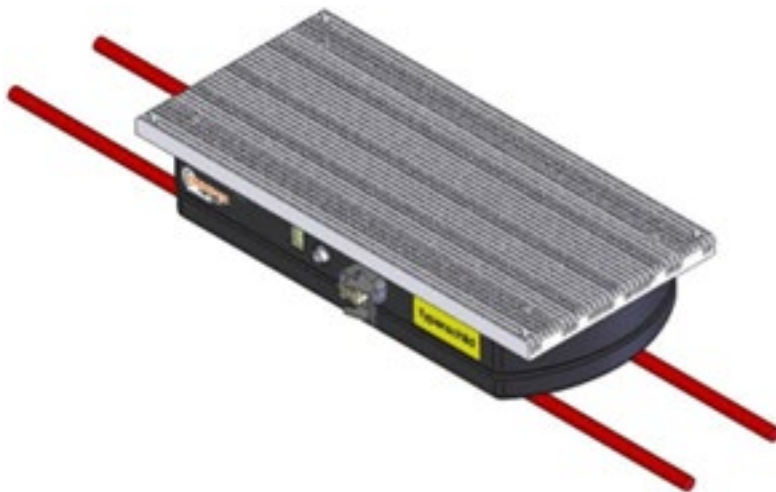

F-Pickup 2.5 kW 560 V DC Q4/2 + Interface M12

7.5.2. Air Flow Required

The heat power of the pickup is dissipated by convection and radiated cooling only. Ensure that free flow of air is guaranteed around the device at all times. It is essential to make sure that the air flow is not hindered in any way by objects and that the device is protected from additional heating, i.e. exposure to sun light or hot air flow from inverters, proximity to brake resistors.

Confined areas should be adequately ventilated, allowing also for the heat generated by the pickup which can reach about 150 W under full load conditions.

Failure to satisfy these requirements may result in reduced performance, damage and/or reduction in lifetime.

7.5.3. Proximity to Iron/Steel

Ferromagnetic material will influence the characteristics of the pickup, i.e. lower output power, production of additional heat/losses, etc. Refer to the entire documentations related to floor systems to make sure that no material in the floor and on vehicles will have a negative impact on the pickup. We strongly recommend to respect the specifications for areas free of ferromagnetic material as shown in the illustration below, and even to go beyond these requirements whenever possible.

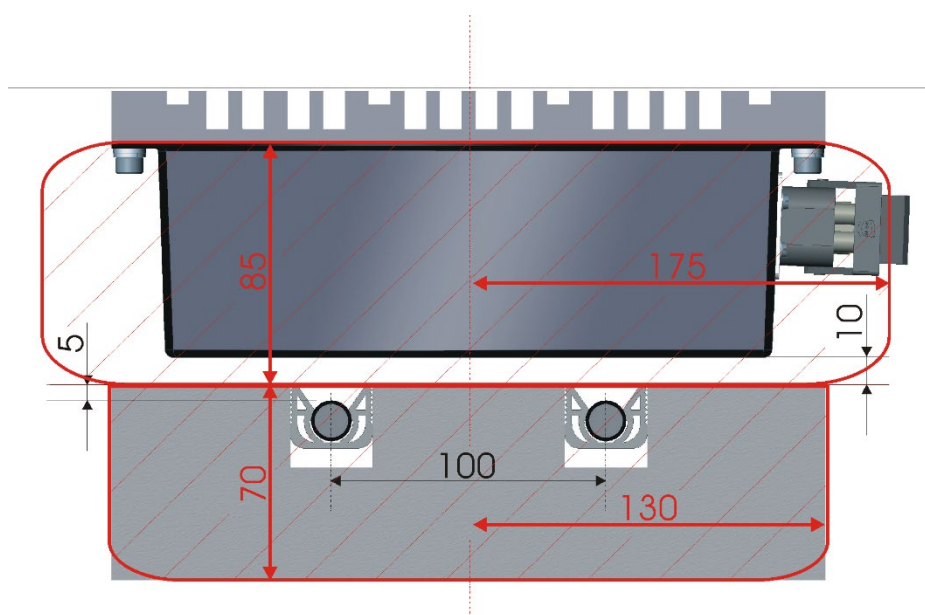

F-Pickup 2.5 kW 560 V DC Q4/2 + Interface M12

7.5.4. Attachment Points

Use M8 (recommended) screws of adequate length to attach pickup to supporting structure.

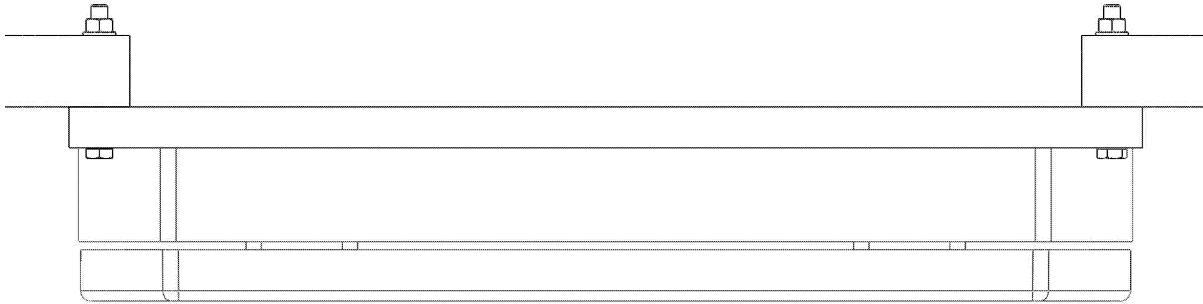

7.5.5. Additional mechanical Protection



Metallic parts may be heated by induction!

Small parts may get very hot. If there is the probability - due to the environment of operation - that small obstacles, and particularly ferromagnetic parts lay on the floor, we recommend the use of an adequate brush or any other sweeping method to push these obstacles out of the way in order to prevent damage to pickups or injuries to persons susceptible to come in contact with the above mentioned heated parts.

8 Operation

8.1. Powering up

The primary track being turned on, once a suitable magnetic field is detected, and if the pilot pins (pins 11 and 12 of the power output connector) are shorted, the pickup will be ready to be turned on. The output voltage will however appear at the power output of the shrouded pin connector only if the pickup is enabled at the interface plug. Enabling the pickup can be done in two different ways:

- 1.) by making a connection between pins 1 (internal isolated 24 V) and 4 (enable),
- 2.) by connecting an external 24 V supply between pins 2 (0 V isolated) and 4 (enable pin). In which case, the + pole goes to pin 4.

Note that when the pickup is in the disable mode (pin 1 and 4 disconnected), the internal isolated 24 V supply is only suitable to supply a starting signal to the pickup itself; do not distribute externally! When the pickup is enabled and the “status” relay is closed (between pins 3 and 7), the maximum current allowed is 150 mA.



When the interface is not used!

Even if signals available through the interface plug are not being used, it is still necessary to connect pin 1 to pin 4 for the regulator to start.

An optional “enable plug” is for that matter available, see chapter 14.2.

8.2. Powering Down

Turning off the primary track will have the immediate effect of turning off all pickups. They do not need to be powered down individually before turning the primary track off. However, since turning off a pickup resets the error mode, turning off a single pickup may be convenient when a fault occurs on a single vehicle. Please, refer to section 10 to find out more on how to reset pickups.

If the need of turning on and off a pickup exists even under load, using the interface plug is the best way to proceed; simply break the contact with pin 4. It is not recommended to use the pilot pins to turn off a pickup under load!

When a pickup is turned off, the energy stored internally is discharged to reduce the output voltage to a minimum. For this reason, the number of times a pickup can be turned off (number of shutdown procedures) is limited to 3 within 30 seconds. Exceeding this limit causes the pickup not to respond and it will remain disabled (off) for the next 30 seconds.

8.3. Positional Tolerances

Since the power rating of a pickup is dependent on the strength of the primary magnetic field, it is also dependent on the relative position of the pickup to the track. The power ratings are defined for a nominal air gap (between floor and pickup) of 10 mm and a horizontal offset of 0 mm, i.e. directly centered over the primary track. The following curves show the typical output power over a normal straight track as a function of ¹⁾ vertical displacement, and ²⁾ horizontal offset.

The non-variable parameter is understood to be at nominal value. The power rating of the pickup will be affected by the layout of the track, i.e. bifurcations, curves, influence of ferromagnetic material, etc. see also chapter 7.5.

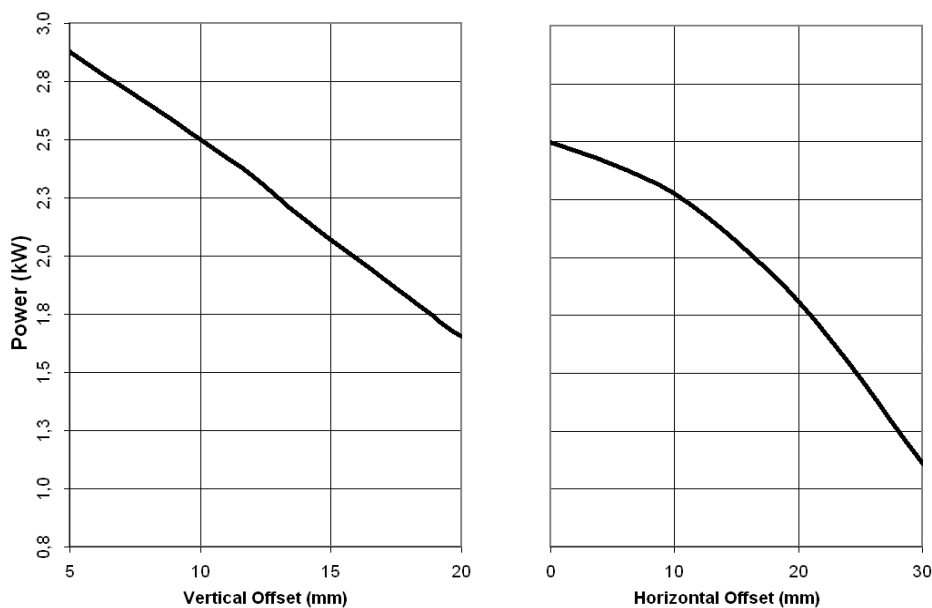

8.4. Parallel Operation of Pickups

The pickups described in this documentation can be operated up to five together in parallel (more upon request). By parallel operation it is understood that only the main voltage output of several pickups are connected together (exception made of the ground connection see chapter 4.5.3). In other words, connections with pins 2, 4, 11 and 12 must remain separate for each pickup.



When several pickups are directly connected to a common bus, voltage will be present if a plug is disconnected on the pickup side. Please note that the interface makes it possible to detect when a power plug is disconnected while other pickups are still powered up, see below.

F-Pickup 2.5 kW 560 V DC Q4/2 + Interface M12

⇒ When the interface is used:

Due to their isolated properties, it is possible to interconnect the M12 interfaces together. However, we recommend to wire each signal separately to determine precisely which signal comes from which pickup and therefore to be able to take corresponding action independently (i.e. if a pickup entered an error mode, it can be reset without having to completely stop the vehicle).

As mentioned above, the detection of a disconnected power plug is possible. A closed "Warning" relay and open "Status" relay, while the controls of the vehicle still provide an "enable" (or ON) signal, is characteristic of such a case and therefore of a possibly unsafe situation if other pickups are still powered up.

8.5. Maximum Number of Pickups on a Track

When the primary track is first turned on, pickups shortly draw a certain amount of energy even if their output is not enabled. A peak of power is therefore required at the start up of the primary track. In the same way, during normal working conditions, power peaks may appear depending on the parameters of the whole system. Because each system is different, there is no general rule about the maximum number of pickups powered by a single track supply. If the peak power of all pickups added together is close to or exceeds the peak power of a track supply, you should contact Conductix-Wampller for a detailed analyze of the system.

8.6. Tips for Operation with the Interface

The signals that are available through the M12 interface plug are described hereafter, including their initial state (open or closed). For more details on available information and diagnose see chapter 10.

- Error relay (pins 3 - 6)

Closes when a magnetic field acceptable to ensure the minimum function is detected, and that no error is present. This is however no guaranty for the deliverable output power (refer to chapter 7.5). Opens when an error is detected.

- Warning relay (pins 3 - 5)

Is normally open. Closes when approaching limits of operations (i.e. temperature, overload) to give the user the opportunity to take the signal into account and prevent an automatic shutdown which could cause the vehicle to stop in a critical zone and/or at a critical moment. Provides also some information on the pilot pin function. See also chapter 8.4.

- Status relay (pins 3 - 7)

Is normally open. Closes when the main output has been enabled and the regulation functions are fully ready for operation with load. The state of this relay is no guaranty for the accuracy of the voltage output i.e. in case of overload the voltage will be lower than the nominal value specified.

8.7. Precautions



Pickups are not designed for independent operation. They have to be operated in conjunction with corresponding Rail components.



Never operate a device showing damage or that is in a non-touch proof state. Do not perform any work on the device while in operation. Life threatening danger of electrical shock!



During or after operation surfaces of the pickup may be hot. Be careful! Prevent access to hot surfaces if necessary. Refer to section 4.4 "Mechanical integration" for more information.

Never short-circuit the DC power output or discharge it into a resistance of less than 20 ohms. This may result in high discharge currents and therefore severe damage may result.

Do not connect or switch a charged or powered pickup directly on to any batteries. Connection should only take place when the pickup is in a powered down state. Never connect a battery load in reverse polarity, damage will occur. Pickups will draw a small amount of power from batteries even if switched off; batteries will discharge.

Ensure adequate ventilation. Refer to chapter 7.5.

9 Warnings and Cautions



All electric work has to be carried out by qualified staff (IEC 364 respectively ENELEC HD 384 or DIN VDE 0100 and IEC 664 or DIN VDE 0110 and national safety rules).

Qualified staff, according to safety regulations, are persons that are familiar with the installation, commissioning and operation of the energy supply systems and that have the appropriate qualifications.



The pickup is only foreseen to be operated in conjunction with matching components. If you are not sure whether components match, contact Conductix-Wamplifier. Do not put into operation before.



Do not install an obviously damaged device. Do not take damaged devices into operation. Severe damage may result. Ensure that protection device and other preventive measures taken comply with the applicable regulations. Make sure that all connected circuits fulfill at least the same safety standards as the pickup and fulfill requirements for safe operation. Make sure that the device cannot start up unintentionally.

Route power and control cables separately so that no interference can occur. Only use cables with a cross-section suitable for the given currents. Note polarity when connecting any device to the output of the pickup. If not observed, severe damage may result.

During or after operation surfaces of the pickup and components inside may be hot. Be careful! Prevent access to hot surfaces if necessary.

Pickups can contain voltage even in a disabled mode (OFF), even if status LEDs have gone out. Do not open, do not insert any objects inside and do not touch connection terminals. The only safe means of working on circuits connected to the device is to ensure that the primary track is switched off and then to disconnect physically the DC power output plug. Make sure that connections are not removed under dangerous conditions, i.e. under load. Allow at least 5 minutes before touching connection terminals to be sure that no energy remains stored internally by capacitors. Improper handling can result in electric shocks or burns as well as damage to the pickup.

Do not perform any work on or around the device while in operation. **Life threatening danger of electrical shock!**

10 Fault and Diagnose

10.1. Basics

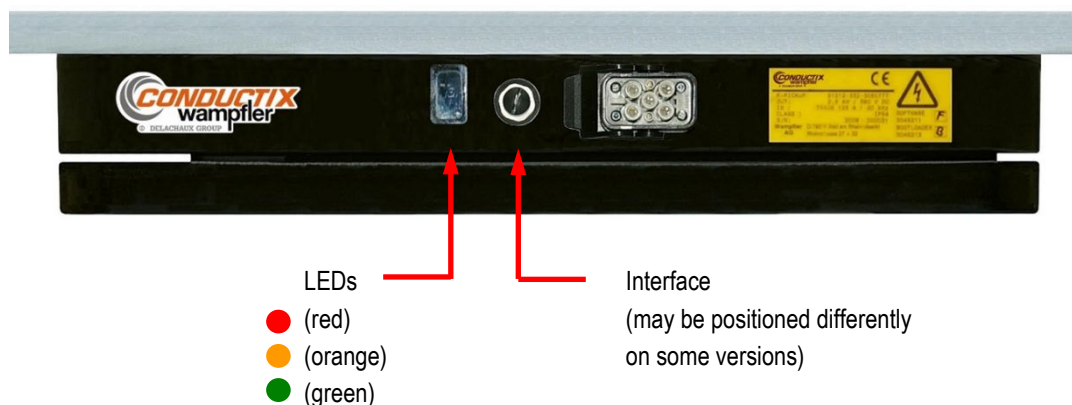

The display has 3 LEDs:

- (red): "Error" LED
- (orange): "Warning" LED
- (green): "Status" LED

The interface plug provides 3 potential free relays with a common pin (pin 3).

For more information on relays, see also chapter 8.6.



- "Error" relay (pins 3 - 6)
Open when primary power absent or in error state. Closed under normal conditions.
- "Warning" relay (pins 3 - 5)
Initially open. Closed only to signal a warning.
- "Status" relay (pins 3 - 7)
Initially open. Closed once the pickup is enabled and ready for operation with load.

The state of operation of a pickup can be determined more precisely using the LED display and the interface plug shown above. Relays and LEDs provide the same information though LEDs may display additional information by remaining on or blinking.



As a general rule, never operate a pickup when it is out of order!

10.2. Normal State

When a pickup is **disabled** (primary track is on but pickup turned OFF) the following information is available:

-  (red): "Error" LED off + "error" relay (pins 3 - 6) closed
-  (orange): "Warning" LED off + "warning" relay (pins 3 - 5) open*
-  (green): "Status" LED **blinking** + "status" relay (pins 3 - 7) **open**

When a pickup is **enabled** (primary track is on and pickup turned ON) and working under normal conditions of operation as specified in this documentation, the following information is available



-  (red): "Error" LED off + "error" relay (pins 3 - 6) closed
-  (orange): "Warning" LED off + "warning" relay (pins 3 - 5) open*
-  (green): "Status" LED **on** + "status" relay (pins 3 - 7) **closed**

* = **Note:** In addition, warning information may be shown through a closed "warning" relay as well as the orange LED being on. This does not necessarily mean that the pickup is being operated under abnormal conditions; it may be that the pickup operates in conditions close to its limits while still within its specifications. Refer to chapter 10.3 for more information about possible meanings of warning signals.

10.3. Signals and Meanings

Warning signals provide detailed information according to how they are displayed (LED blinking or not) and in which context (which state for other LEDs/Relays). Refer to table 1 for information based on relay states and to table 2 when based on LED display.

Note that if the primary track supply is not on or if the pickup is not correctly positioned over the primary track cable, all the LEDs are off and all the relays are open:

-  (red): "Error" LED off + "error" relay (pins 3 - 6) open
-  (orange): "Warning" LED off + "warning" relay (pins 3 - 5) open
-  (green): "Status" LED off + "status" relay (pins 3 - 7) open

F-Pickup 2.5 kW 560 V DC Q4/2 + Interface M12

If the above situation happens (all LEDs off + all relays open) despite the fact that the primary track is on and that the pickup is centered over the track - any part of the track! - and also positioned with nominal air gap, then the pickup is out of order.

Never operate a pickup when it is out of order!

	Status relay closed	Status relay open	Error relay open
Warning relay is closed	see a) or b)	see c)	see d)
Warning relay is open	Normal operation: see chapter 10.2	Normal operation: see chapter 10.2	see e)

Table 1: Relay outputs and meaning







	 Green LED remains ON (Status relay closed)	 Green LED is blinking (Status relay open)	 Red LED remains ON (Error relay open)
Orange LED remains ON  (Warning relay closed)	see a)	---	---
Orange LED is blinking  (Warning relay closed)	see b)	see c)	see d)
Orange LED is OFF  (Warning relay open)	Normal operation: see chapter 10.2	Normal operation: see chapter 10.2	see e)

Table 2: LED display and meaning

- The maximum peak power available is exceeded. Refer to chapter 4.1 "Electrical Data", 7.5 "Place and Conditions of Installation" and 8.3 "Positional Tolerances" to make sure the requirements in peak power match the actual conditions of operation.
- The internal temperature is approaching maximum ratings. If the average power consumed is compatible with the specified technical data (chapter 4.1 and 4.2) and together in accordance with chapter 7.5 "Place and Conditions of Installation", this warning will have no consequence and the system may be further operated as it is. On the other hand, if such a warning appears in the long run, whereas it was never displayed before, this may indicate for example a strong soiling of the cooling elements and we therefore strongly recommend referring to chapter 11 "Maintenance". This situation may lead to an over temperature error: see case d).

F-Pickup 2.5 kW 560 V DC Q4/2 + Interface M12

- c) Automatic shutdown initiated by the pilot pins function; the power plug is not connected. If the enable (or ON) signal is present on other pickups connected together, dangerous voltage may be present at the disconnected cable. For more information on the pilot pins and their function please refer to chapters 4.3, 4.5.1, 7.4, 8.1, 8.2 and 8.4. Check also that AC1-AC2 are not connected.
- d) The maximum internal temperature has been exceeded. The warning signal (LED blinking or relay closed) will remain until the internal temperature has decreased to an adequate value. The pickup will however remain in an error mode until it is reset (see chapter 10.4). Check the compatibility of the average power required with the device specifications („Technical data“ chapter 4.1 and 4.2) and the cooling requirements („Place and conditions of installation“ chapter 7.5).
- e) The pickup has automatically shut down. See chapter 4.3 “Protection Measures” for some information. Reset the pickup (see chapter 10.4) and observe the conditions of operation if the fault were to reproduce. If a fault cannot be attributed to external conditions of operation the device is out of order and needs to be repaired by a specialist. Refer then to chapter 12 “Repair”.

10.4. Reset

When the interface is used:

If a connection with the interface plug is available, resetting a pickup after a fault simply requires to disable it (open contact pin1 - 4) then to enable it again (close contact pin1 - 4).

When the interface is not used:

When it is not possible to proceed in this way because the interface is not used, resetting a pickup can be done using the pilot pins; disconnecting then reconnecting the pilot pins together will reset the pickup. Attention: pilot pins are not designed to be used as an ON/OFF switch and it is thus recommended not to open the pilot connection under load.

In all cases:

Maximum number of shutdown or disable procedures: 3 times over 30 seconds. The pickup will then automatically restart after this delay if enabled (i.e. if pin 1 and 4 are connected together).

Moving the pickup away from the track, or turning off and back on the primary track supply will also reset the pickup.

11 Maintenance



There is no specific maintenance required other than checking regularly that a free air flow for cooling is given and that there are no damages visible from the outside. Strong soiling or obstacles on the heatsink that would prevent sufficient cooling conditions should be avoided.



Any repair work is only possible at Conductix-Wamplifier. See also chapter 12 „Repair“.

12 Repair



WARNING!

If a fault cannot be attributed to external conditions of operation, the device needs to be repaired by a specialist.

Unless otherwise arranged, return parts to your nearest Conductix-Wamplier facility or to Conductix-Wamplier for repair. Before returning any parts contact Conductix-Wamplier for specific instructions.

Be sure to include the following information when returning parts to Conductix-Wamplier:

- Product name
- Material number
- Serial number
- Application/Installation, in case with a brief description
- Wiring schematic of overall system, if at hand
- Fault description
- Circumstances the fault occurred at, especially if any unusual events preceded the fault
- Presumption what could have caused the fault
- Photo, if available

13 Disassembly and Re-Use



If it is necessary to exchange a pickup due to damage or to install it in another place, verify that no damage will occur during disassembly.



For installation in another place observe the described mounting and commissioning instructions. Improper application, wrong installation or operation involve the danger of severe injuries to persons and damage to objects.

All electric work has to be carried out by qualified staff (IEC 364 respectively, CENELEC HD 384 or DIN VDE 0100 and IEC 664 or DIN VDE 0110 and national safety rules).

Qualified staff, according to the safety regulations, are persons that are familiar with the installation, assembly, commissioning and operation of the energy supply system and that have the appropriate qualifications.

13.1. Safety Advice for Disassembly and Disposal



1. Disconnect the system from the mains voltage
2. Make sure that the system cannot be powered up again accidentally



3. After disconnecting the track supply from the supply voltage wait at least 5 minutes for internally stored energy to discharge.
4. Dismount the device
5. Dispose of components in a specific way → Recycling

13.2. Recycling

The unit contains components that have to be disposed of in a specific way. If it is not used any longer, it will have to be recycled properly. Dispose the materials separately in accordance with the current regulations, i.e. separate circuit boards, aluminum heatsink, cable (copper), etc. or hand over the unit to a recycling specialist.

F-Pickup 2.5 kW 560 V DC Q4/2 + Interface M12

14 Accessories

14.1. Power Output



A 5 meter long cable, preassembled with one male connector on one side, can be ordered separately through Conductix-Wamplifier under material number: 91212-339-3104944.

Pin 2 and pin 4 are not connected.

Otherwise, the following components are needed for the connection to the pickup. Special tools are then needed for the assembly. See chapter 15.

Description	Quantity needed	Material Number Ilme	Material Number Harting
Hood (thermoplastic)	1	CQ08VK	19 12 008 0429
Cable gland (thermoplastic)	1	CRQ16	19 12 005 5157
Crimp terminal, male insert	1	CQM04/2	09 12 006 3041
Power crimp contact, male 1,5 mm ² 2,5 mm ²	3 (One type only!)	CXMA1.5 CXMA2.5	09 32 000 6104 09 32 000 6105
Control crimp contact, male 1,5 mm ² 2,5 mm ²	2 (One type only!)	CDMA1.5 CDMA2.5	09 15 000 6101 09 15 000 6106

F-Pickup 2.5 kW 560 V DC Q4/2 + Interface M12

14.2. Interface



A 5 meter long cable, preassembled with one male connector on one side, can be ordered separately through Conductix-Wampfler under material number: 91212-339-3047358.

A compact enable plug allowing an automatic start-up of a regulator is also available for order through Conductix-Wampfler under material number: 91000-400-3089971

Note: This plug does not allow any remote ON/OFF function nor any of the diagnoses possibilities. Refer to the product documentation for more information.

Otherwise, you can find in the table below a choice of possible solutions for the connection to the interface:

Description	Material number Phoenix	Material number Binder
5 m shielded cable, preassembled with 1 male connector	1407848	79 3579 3508
5 m unshielded cable, preassembled with 1 male connector	--	79 3479 3508
Male connector, preassembled with wires	1523492	09 3481 700 08
Male connector, with solder terminals only	1542758	--

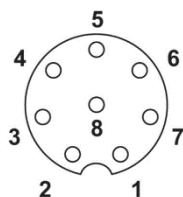

The information below is for reference only. It relies on the 2012 specifications of the manufacturers for the material mentioned in this paragraph only. In case of any doubt, or when using different material than those mentioned above, it will be necessary to check the correspondence between the pin number and the color of each wire in order to avoid possible damage to connected devices.

- PIN 1 > white
- PIN 2 > brown
- PIN 3 > green
- PIN 4 > yellow
- PIN 5 > grey
- PIN 6 > pink
- PIN 7 > blue
- PIN 8 > red or shield

15 Tools



There are no special tools required other than for the assembly and/or disassembly of the separate parts listed in chapter 14.1 for the power connector:

Description	Manufacturer	Material number
Crimping tool Han C and HAN D type contacts	Harting	09 99 000 0021
Removal tool for Han C contacts (Power crimp contacts)	Harting	09 99 000 0305
Removal tool for Han D contacts (Control crimp contacts)	Harting	09 99 000 0052

Conductix-Wamplfer GmbH
Rheinstraße 27 + 33
79576 Weil am Rhein - Märkt
Germany

Phone: +49 (0) 7621 662-0
Fax: +49 (0) 7621 662-144
info.de@conductix.com
www.conductix.com



Importer for the United Kingdom:
Conductix-Wamplfer Ltd.
1, Michigan Avenue
Salford
M50 2GY
United Kingdom

Phone: +44 161 8480161
Fax: +44 161 8737017
info.uk@conductix.com
www.conductix.com